

A

B

C

D

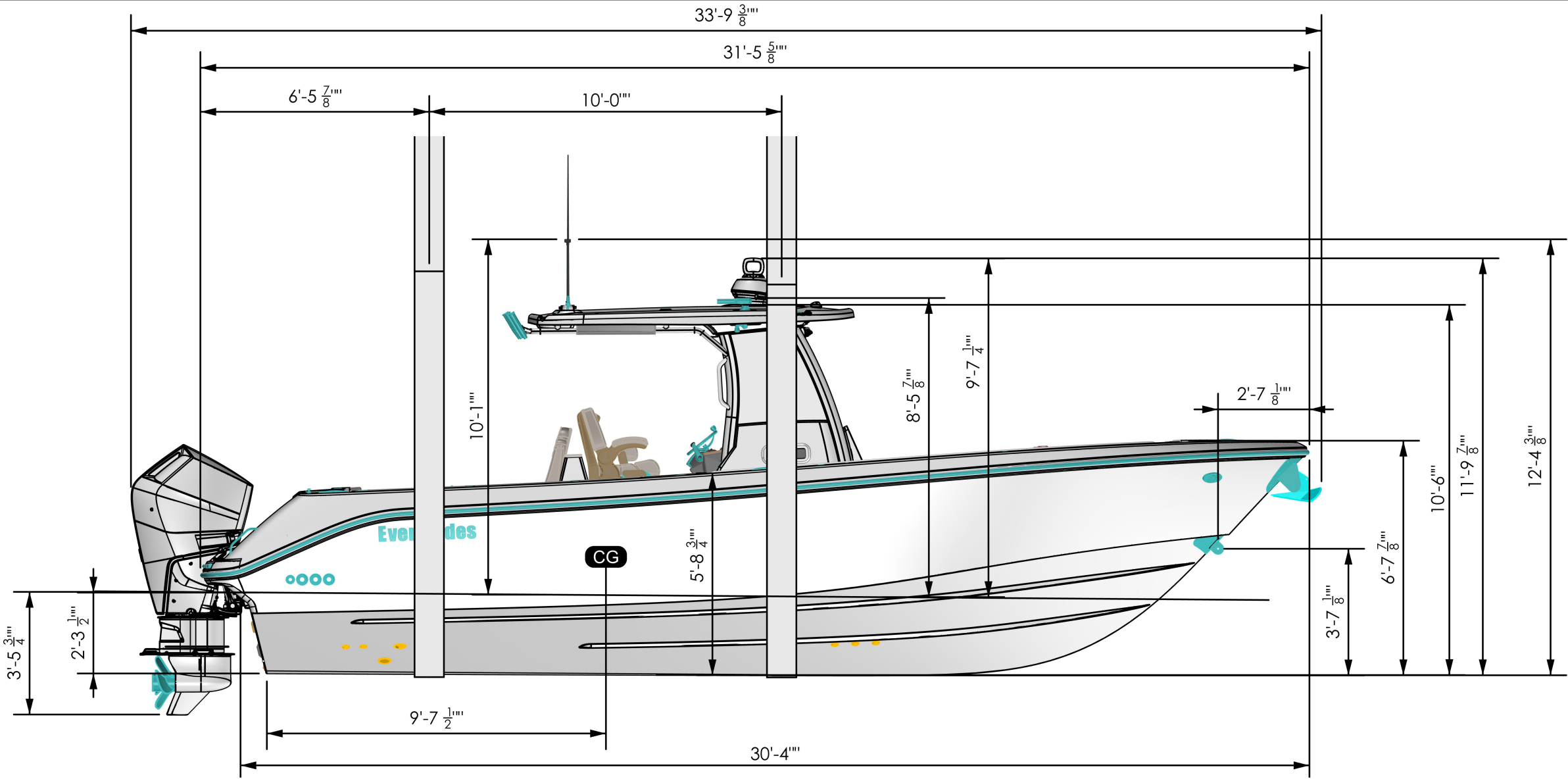

- NOTES:
- 1) APPROXIMATE DRY WEIGHT WITH MERCURY V10 400 ENGINES (WITHOUT OPTIONS) 11,500 LBS
 - 2) APPROXIMATE WEIGHT WITH FULL FUEL & WATER, INCLUDING SEAKEEPER SK2 & OPTIONS 14,250 LBS
 - 3) WATERLINE & CENTER OF GRAVITY SHOWN WITH FULL FLUIDS & OPTIONS
 - 4) THE MAST LIGHT CAN BE FOLDED DOWN
 - 5) WHEN BLOCKING THE BOAT USE A LEAST THREE EQUALLY SPACED POINTS ON THE KEEL AND AT LEAST TWO POINTS ON THE CHINES

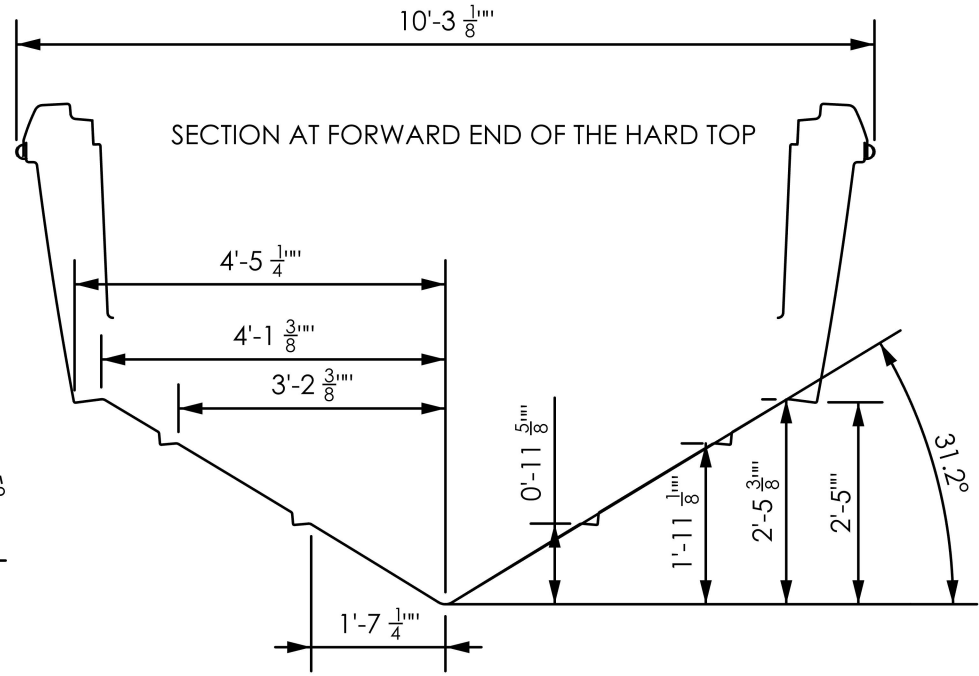
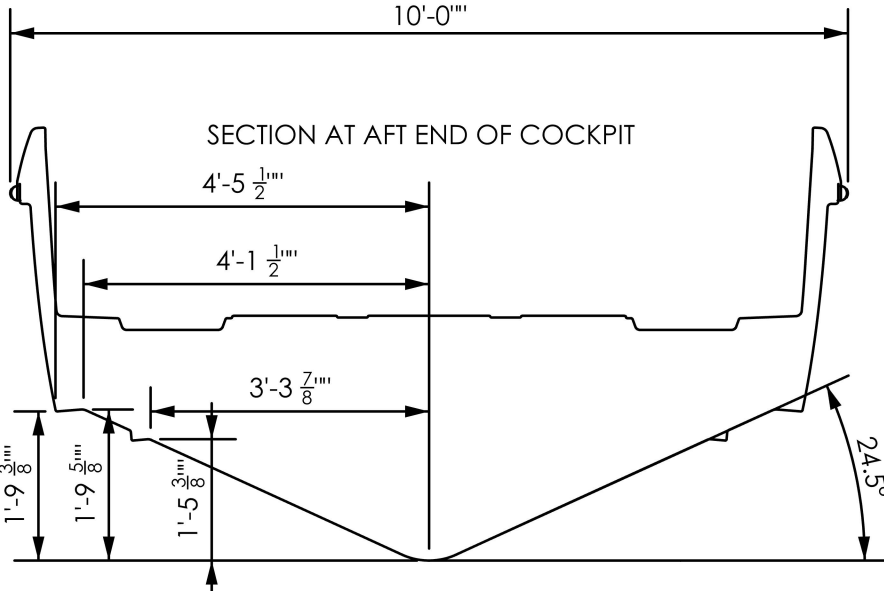

REV	DESCRIPTION	DATE	#1	CLW	APPR BY
A	ADJUSTED WEIGHT AND CENTER OF GRAVITY TO REFLECT VALUES MEASURED FROM HULL #1	8-2-23			

EVERGLADES
RJ Dougherty Associates
544 S Airpark rd.
Edgewater, FL 32132-3043
386-4092202

Title:	GRAVING PLAN		Scale:	1:1	Dwg No:	315-M-1	Drawn by:	CLW	
	Model:	315CC		Part No.				Sheet:	1 OF 1
		Date:	8/2/2023					Chkd by:	